

CHARACTERISTICS

WORKTOPS

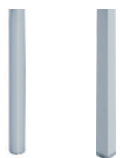

<p>MELAMINE</p>	<ul style="list-style-type: none"> > Melamine covered particle board panels, 38 mm or 30 mm thick. 2 sides treated with an anti-reflective coating Panel density 630 to 640 kg/m³. Flat edge banding (2 mm thick) made from a strip of glued ABS with rounded edges. Edge banding to match worktop finish Panels sourced from sustainably managed forests (PEFC). Fire rating M3 (combustible, moderately flammable) in accordance with the standard NF EN 13501-1 Panels are certified E1 (control of formaldehyde emissions), emitting 6.5 mg HCNO/100 mg and compliant with standard NF EN 717-2 All melamine panels have an antibacterial surface that meets standard ISO 22196. > Reinforcement beams for 90° corner angle worktops D. 1350 mm and rectangular worktops L. 1800 mm > Option for worktops pre-cut for top-access housings (rectangular and curved worktops only) Top-access housings to be ordered separately (see Options below) - Metal cable trough included.
-----------------	--

LEGS AND STRUCTURE

<p>MELAMINE PANEL</p> 	<ul style="list-style-type: none"> > Melamine panel leg 38 mm or 30 mm thick, matching worktop Shared or independent leg, depending on the configuration selected Assembly on metal inserts 3 leg types: symmetrical, asymmetrical or angled Legs with adjustable stabiliser feet, adjustable through 15 mm.
<p>METAL</p> 	<ul style="list-style-type: none"> > Circular section legs in tubular steel ø 70 mm > Square section legs in tubular steel 60 x 60 mm > Shared or independent leg, depending on the configuration selected > Lower part with chromed end housing the adjustment mechanism > Adjustable stabiliser in translucent ABS. Adjustment through 20 mm. > Upper plate in sheet steel with brace

CHARACTERISTICS

OPTIONS

<p>WORKTOP POWER & CABLE MANAGEMENT</p> 	<p>Plain cable ports</p> <p>Cable ports for direct connectivity</p> <p>Cable ports with sliding covers for direct connectivity</p> <p>Top-access modules with or without a socket feed</p> <p>See corresponding Technical Data Sheets for details.</p>
<p>CENTRAL TOP-ACCESS HOUSINGS AND CABLE TROUGHS FOR ELLIPTICAL TABLES</p> 	<p>Elliptical tables can be fitted with central cable troughs with top access housing in metal or Altuglas® finish.</p> <p>These top-access housings have slots for the passage of cables and adapt to the worktop thickness by means of adjustable supports.</p>
<p>MODESTY BOARD</p> 	<p>Sheet steel thickness 0.7 mm, with three horizontal grooves. Finish to match the finish of the legs.</p> <p>2 vertical braces are welded to the inner face.</p> <p>Secures with 2 metric screws M6x12 on inserts positioned beneath the melamine worktop.</p> <p>Total overall height beneath the worktop: H. 280 mm</p> <ul style="list-style-type: none"> - For worktop L 1800: mm: L 1670 mm - For worktop L 1400 mm (rectangular and curved): L 1270 mm - For 90° corner angle worktop L 1350 mm L 505 mm - For trapeziform worktop: L.900 mm (secured using wood screws) <p>Not compatible with worktops fitted for top-access housings</p>

Made
in France



OVERALL DIMENSIONS (in mm)				
RECTANGULAR WORKTOPS				Direction of grain
	Depth	700	700	
	Width	1400	1800	
	Fixed leg height	740 / 748	740/748	

CURVED WORKTOPS	SYMMETRICAL	ASYMMETICAL L	ASYMMETICAL R	
	Depth	700 / 780	700 / 850	700 / 850
	Width	1400	1400	1400
Fixed leg height	740 / 748	740 / 748	740 / 748	

CORNER + ELLIPTICAL WORKTOPS	CORNER WORKTOP	ELLIPTICAL WORKTOP	
	Depth	700 / 1350	900
	Width	700	1400
Fixed leg height	740 / 748	740 / 748	

CABLE TROUGH KIT	TABLE DIMENSIONS	TOP-ACCESS DIMENSIONS	NUMBER OF CABLE TROUGHS	TOP-ACCESS
	L. 3200 x D. 1560	L. 1278 x D. 155	1 x L. 1400	1 elliptical
	L. 4600 x D. 1700	L. 2673 x D. 298	2 x L. 1400	2 end pieces
	L. 6000 x D. 1700	L. 4071 x D. 298	3 x L. 1400	2 end pieces + 1 central L. 1400
	L. 6400 x D. 1700	L. 4471 x D. 298	1 x L. 1800 + 2 x L. 1400	2 end pieces + 2 central L. 900

Made in France

